

gea / speed / maxima

horizontal machining centers



CMS is part of SCM Group, a technological world leader in processing a wide range of materials: wood, plastic, glass, stone, metal and composites. The Group companies, operating throughout the world, are reliable partners of leading manufacturing industries in various market sectors, including the furniture, construction, automotive, aerospace, ship-building and plastic processing industries. SCM Group coordinates, supports and develops a system of industrial excellence in 3 large highly specialized production centres employing more than 4,000 workers and operating in all 5 continents. SCM Group: the most advanced skills and know-how in the fields of industrial machinery and components.

CMS SpA manufactures machinery and systems for the machining of composite materials, carbon fibre, aluminium, light alloys, plastic, glass, stone and metals. It was established in 1969 by Mr Pietro Aceti with the aim of offering customized and state-of-the-art solutions, based on the in-depth understanding of the customer's production needs. Significant technological innovations, originating from substantial investments in research and development and take-overs of premium companies, have enabled constant growth in the various sectors of reference.



CMS Glass Technology is a leader in the field of curved and flat glass working with technologically advanced solutions such as numerically controlled machining centres, cutting benches and water-jet cutting systems. Thanks to the tradition and experience of the historic brands Brembana and Tecnocut, today **CMS Glass Technology** is an absolute protagonist in this sector for the manufacturing of innovative solutions dedicated to architecture and interior decoration.



gea / speed / maxima

APPLICATIONS	4-5
GEA TECHNOLOGICAL BENEFITS	6-7
SPEED MB TECHNOLOGICAL BENEFITS	8-9
SPEED TWIN TECHNOLOGICAL BENEFITS	10-11
MAXIMA MB TECHNOLOGICAL BENEFITS	12-13
MAXIMA OPEN FRAME TECHNOLOGICAL BENEFITS	14-15
ACCESSORIES	16-19
SOFTWARE	20-21
OVERALL DIMENSIONS AND TECHNICAL DATA	22-27
CMS CONNECT	28
CMS ACTIVE	29
THE RANGE	30-31

APPLICATIONS



doors | stairs | shower enclosures | façades and windows | vanity tops



mirrors | tables | oven and stove tops | curved, bullet-proof and safety glass

Winning.
Innovative.
Durable.
Efficient solutions.

Our **WIDE** range for glass processing.

Horizontal machining centers

GEA

TECHNOLOGICAL BENEFITS



LEARN MORE

3-4-AXIS HORIZONTAL MACHINING CENTER

3 or 4-axis (optional) Numerically Controlled machining center to machine both thin and thick flat glass as well as laminated glass and bullet-proof glass. This machine can perform all types of grinding, polishing, drilling, milling, sawing with diamond blade, V-Grooving, engraving, and 5° bevelling.

- gantry system on the Y-Axis provides the bridge motion via two brushless servo motors synchronized by the Numeric Control, in order to ensure extreme accuracy by reducing positioning errors caused by mechanical elasticity
- large duraluminum work surface. The 780 mm (31 in) worktable height makes it easier to load and unload
- monoblock, ribbed, electrically welded, and stress relieved ultra-thick steel base guarantees sturdiness and rigidity for difficult machining work and the longevity of the machine
- pre-setting is integrated into the tool magazine as to not infringe on the working area of the table
- dynamic compensation of the polishing wheels for excellent machining quality



KEY BUYER BENEFITS

- + **Solid aluminium surface:** 18mm, duraluminum worktable for greater stability and durability. The table can be re-surfaced over 10X times.
- + **Limitless magazines:** the extensive modularity of the magazines means the machine can be adapted for any requirement. The magazines can be installed at the back, on the sides, or even under the bridge for a 9.5 second tool change.
- + **Easy loading:** the worktable's height of 780 mm (31 in) and reduced distance of the table from the operator, places CMS Gea at the top of its class for loading ergonomics.



Under-beam tool holder with up to 24 cone positions.

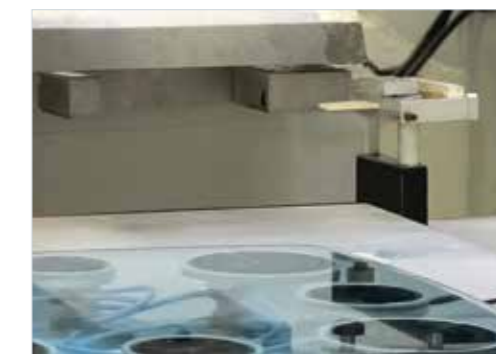

Pre-setting is integrated into the tool magazine as to not infringe on the working area of the table. Diamond and polishing tool dressing unit to ensure top performance of tools at all times.



Automatic lubrication system.

SPEED MB

TECHNOLOGICAL BENEFITS



LEARN MORE

3-4 AXES HORIZONTAL MACHINING CENTER

3-4 axes (on request) Numerically Controlled machining center for the Processing of thin and thick flat glass sheets for both laminated and bullet-proof glass. It carries out any type of grinding, polishing, drilling, milling, cutting with disk, engraving, writing and 5° beveling operations.

- y-axis gantry system provides the crossbeam motion via two brushless motors synchronized by the NC, in order to ensure maximum accuracy and reduction in positioning errors that are due to mechanical elasticity
- large-sized duraluminum work surface. The above ground height of 500 mm facilitates access to the machine and makes the glass sheet loading/unloading operations easier
- ultra-thick and normalized electrowelded ribbed steel monolithic base ensures sturdiness and rigidity for heavy-duty operations and durability
- the machine is adaptable to any need due, thanks to the high configurability of the tool rack
- dynamic compensation of the polishing wheel for better machining quality
- working water collection tank integrated with the base which reduce the machine's footprint



KEY BUYER BENEFITS

- + **Comfortable loading:** thanks to the automatic doors the machine can be loaded and downloaded automatic from an automatic charger, while ensuring the total occupational safety for the operator.
- + **Solid aluminum worktop:** duralumin worktop 18 mm thick, for greater stability and durability. The table allows being adjusted more than 10 times.
- + **Limitless tools rack:** the wide modularity of the tools rack allows to adapt the table to each need. The warehouses can be installed rear, side or also under the beam for a tool change in less than 10 seconds.

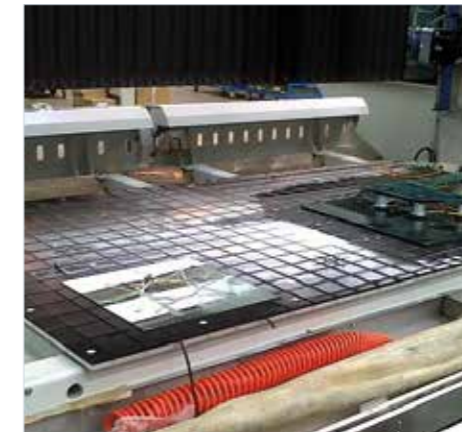

Fully rubberized suction work surface.



Automatic lubrication system



5° beveling tool holder.



Under-beam tool holder with up to 24 cone positions.

SPEED TWIN

TECHNOLOGICAL BENEFITS

3-4 AXES TWIN-HEAD MACHINING CENTER

To increase productivity, CMS offers the Brembana Speed Twin solution with 3- or 4-axis and two heads, which allows two identical workpieces to be machined simultaneously, reducing the production time in half.

The two heads, mounted on the same crossbeam, are independent along the horizontal stroke; in this way, the spindles can be released from one another to perform machining operations with a single head too. Each zone can also be equipped with more than one workpiece per area, thus reducing downtime for equipping the machine

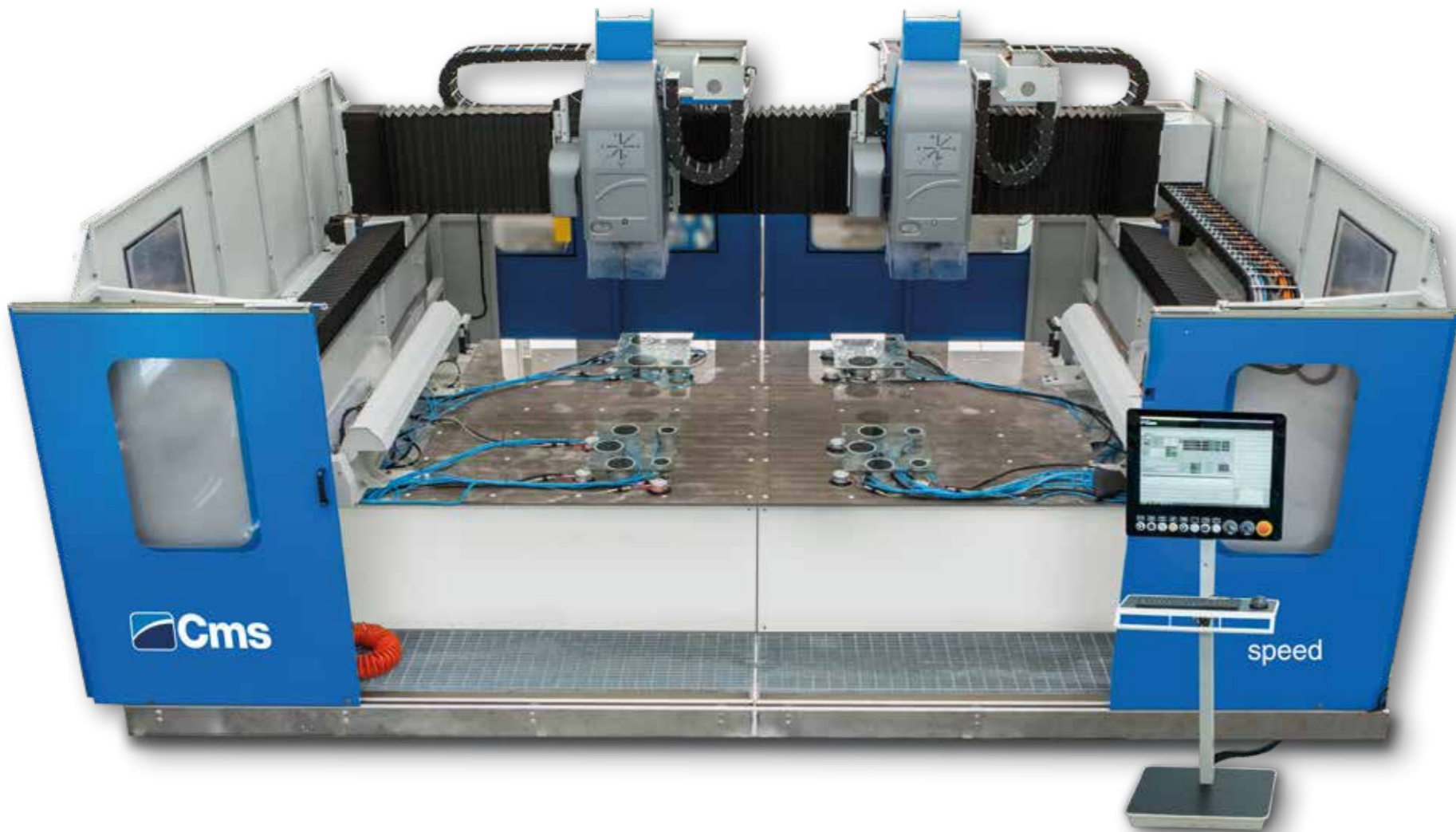

It is possible to install laser presetting in the tool rack for better protection from water and to optimize the use of the table.



SMARTENER FOR TOOLS

Thanks to the device, diamond wheels can be dressed fully automatically at a set frequency. This system is fully automatic and enables using tools in total safety while ensuring maximum performance.

KEY BUYER BENEFITS

- + **Double productivity:** in the Twin version, thanks to the independent double head, productivity increases by up to 53%. Speed Twin, the only machine with two heads and 4 axes on the market, allows simultaneous drilling on identical pieces.

SPEED TWIN

WORKABLE DIMENSIONS WITH 3-AXIS AND 100 MM GRINDER

1 HEAD	2700 x 2000 mm / 106x79 in and rear tool rack
2 HEAD	1700 x 2000 / 67x79 in and rear tool rack

MAXIMA MB

TECHNOLOGICAL BENEFITS



LEARN MORE

5-AXIS HORIZONTAL MACHINING CENTER

5-axis interpolated Numerically Controlled machining center with automatic tool change for the working of flat glass sheets of all thicknesses and bent glass. It carries out all types of edge grinding and polishing, arising, milling, cutting with disk, drilling, contouring, engraving, writing, variable-angle beveling operations and special machining. It's the sturdiest machining center in the field, which makes it ideal for any type of working condition.

- wide rotation of axes C (4th axis) and B (5th axis) for the realization of 0-90° variable-angle beveling and dynamic variation of the bevel depth. The configuration with diamond disk is also available for straight and inclined cuts
- Z-axis stroke from 460 to 900 mm for the most demanding works on bullet-proof, military, aerospace and special glass sheets
- thanks to the high configurability of the machine, it is possible to process glass sheets in massive sizes



KEY BUYER BENEFITS

- + **Ideal for bended glass:** Z-axis up to 2000mm for machining of curved glass. These benefits are particularly useful in processing of aerospace glass where the rays of curvature and size of the glass require precision and high strokes.
- + **0 loading/unloading time:** the machine can be configured to work in pendulum mode and total safety for the operator. In this way, the loading and unloading times are zeroed. Removing the bulkhead that separates the two areas it is possible to work a glass of more than 10 meters.
- + **100% Automatic project correction:** to ensure perfect processing of bent glass, the machine probes the piece by correcting the discrepancies in the drawing provided. In this way the size of the fillets along the entire glass uniform.
- + **Limitless tools rack:** the wide modularity of the tools rack allows to adapt the table to each need. The warehouses can be installed rear, side or also under the beam for a tool change in less than 10 seconds.



Thanks to the telescopic front doors, the operator works in a fully protected environment. The doors also guarantee a water proof seal inside the machine.



Thanks to the power of the spindle, it is possible to mount cutting discs to eliminate excess material. Especially recommended when machining complex geometric shapes on laminated glass.



The 5-axis head allows any type of machining to be carried out without any limits. Chamfering or cup grinding can be carried out without using any aggregate tool.



N.T.S. (No Template System) is the revolutionary system that enables chamfering of thin glass sheets without having to resort to generating a template. A supporting integral with the operating head supports the glass sheet during the chamfering process so that the final result is consistent and uniformed work along the entire glass sheet.

MAXIMA OPEN FRAME

TECHNOLOGICAL BENEFITS

3, 4 OR 5-AXIS HORIZONTAL MACHINING CENTERS

3, 4, or 5-axis numerically controlled machining centers with separate supports (Open Frame). The Z-axis from 600 to 2000 mm enables carrying out the most unique and exclusive operations, such as safety glass sheets and special bullet-proof glass sheets for the aerospace industry and nuclear power plants as well. The Open Frame versions enable working in alternating modes with complete safety conditions thanks to the 2000 mm high central protection separating the two working areas, in full compliance with the international safety standards.

- standard separate supports in concrete or steel (optional)
- with the Twin configuration it is possible to work in an alternative mode in full compliance with the international safety standards
- machine adaptable to any working needs thanks to the high configurability of the work surface, Y-axis stroke, and tool rack

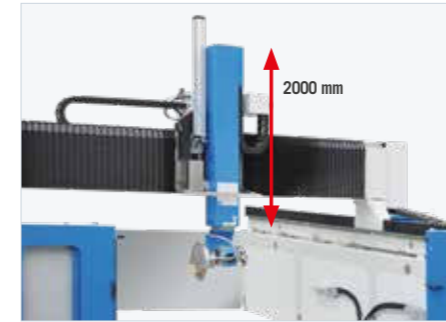
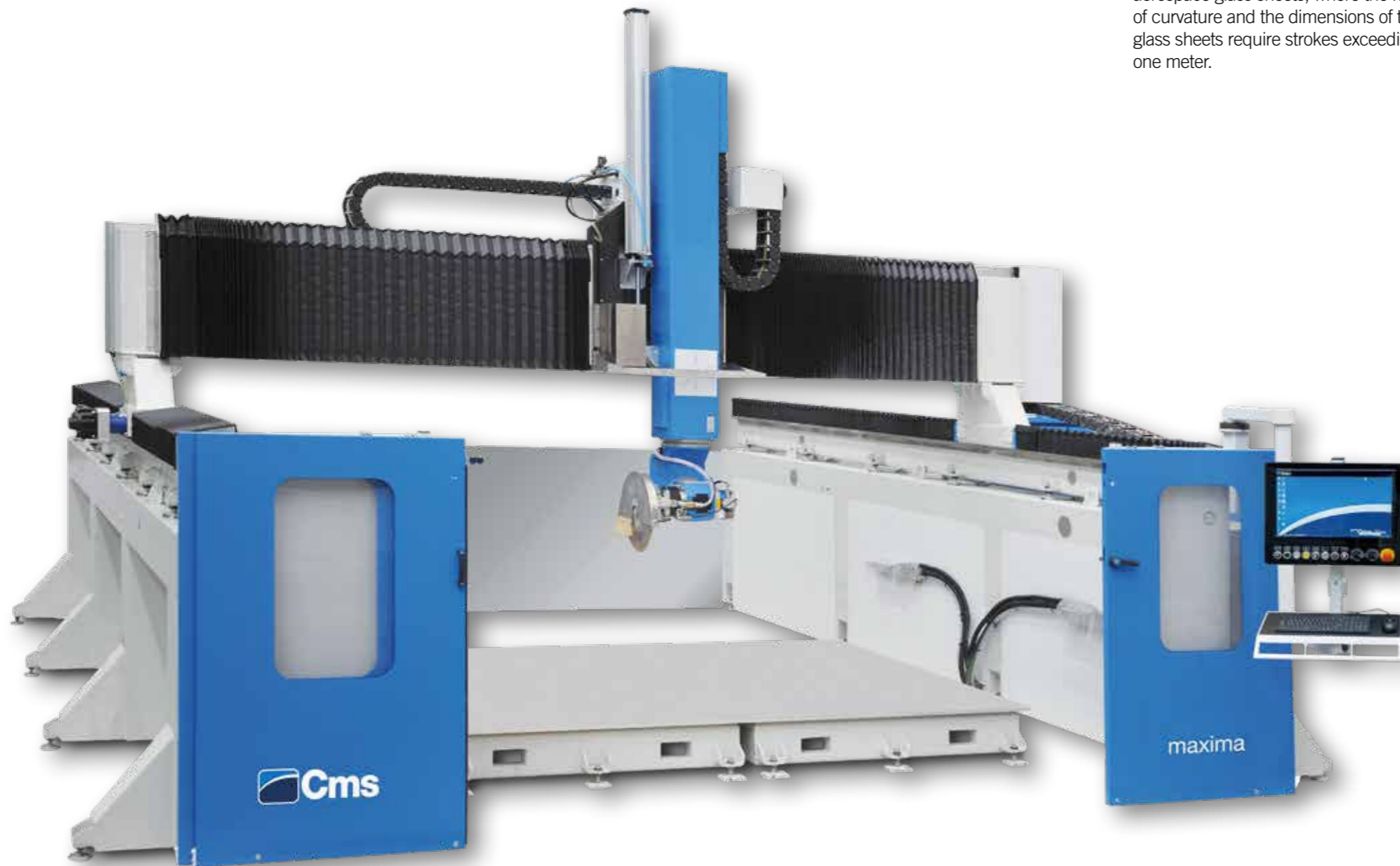

Z-Axis up to 2000 mm for the machining of curved glass sheets. This performance is particularly useful in the machining of aerospace glass sheets, where the radius of curvature and the dimensions of the glass sheets require strokes exceeding one meter.



Version with dual work surfaces. The machine can be configured to work in pendular mode and in total safety for the operator. If necessary, by removing the bulkhead separating the two zones, it is possible to work with a larger table.

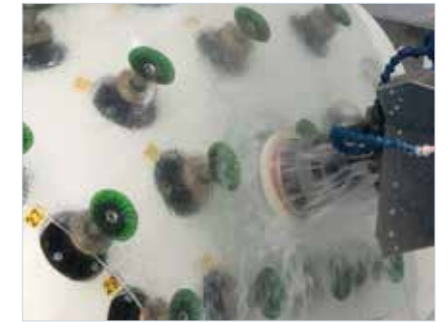

Pop-up suction cups for the machining of curved glass sheets. Using specific templates it is possible to machine thin curved glass sheets. The machine guides the operator in positioning the suction cups and the workpiece.

MAXIMA OPEN FRAME TECHNICAL DATA	
X AXES STROKE	3800 ÷ 4250 mm / 149 ÷ 167 in
Y AXES STROKE	3000 ÷ 7200 mm / 118 ÷ 283 in (configurations available with Y>283 in)
Z AXES STROKE	600 ÷ 2000 mm / 24 ÷ 79 in

ACCESSORIES

The wide modularity of our factory allows us to customize a table to every need. The magazines can be installed at the rear, along the side or even under the crossbeam for an extremely quick tool change.



CERIUM OXIDE TANK

For an extraordinary quality of polish, it is possible to use a felt that is cooled by cerium oxide. The tank continuously mixes the liquid and sprays it directly onto the working area.



AUTOMATIC SYSTEM FOR CONE CLEANING

Thanks to this system, it is possible to keep the cones in perfect condition at all times.



PNEUMATIC BARS ASSISTING GLASS SHEET LOADING

Thanks to these bars, large glass workpieces can be easily loaded even when no automatic lifting devices are available. After positioning the workpiece, the bars disappear under the surface of the suction cups.

TOOL HOLDER CONES

The CNC works with ISO40 cones; it is possible to use peripheral grinding cones, 1/2 gas cutters and core drills, as well as cones for chamfering wheels and angular transmissions.



UNDERCUT DRILLING UNIT WITH ANGULAR TRANSMISSION

By using this device, it is possible to drill holes without splinters even on thin glass sheets.

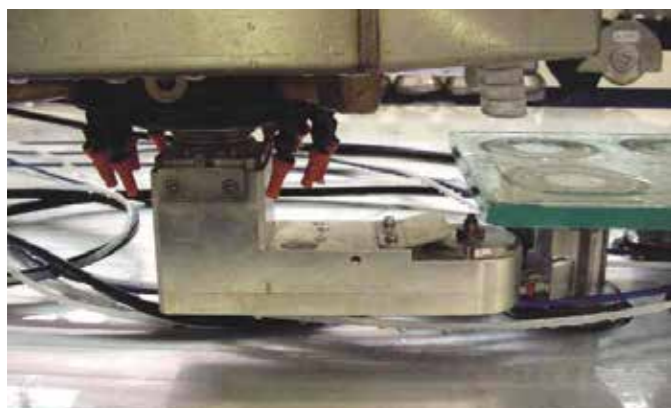

MACHINING WATER RECYCLE TANK

The tank for the recirculation of the external machining water is built within the machine structure. This makes cleaning easier and ensures that there is no water outside the CNC.



ACCESSORIES

TOOL LASER MEASURING UNIT

The automatic tool-measuring unit, apart from speeding up the operations in using a new tool, enables dimension detection its dimensions with centesimal precision. This way, the tools works the glass piece at their maximum performance, guaranteeing less wear and better quality.



Electrospindle 30 kw.



COPYING OF TEMPLATES WITH LASER

The machine can automatically detect any templates positioned on the work surface. Thanks to this characteristic, it is possible to acquire automatically machine complex geometric shapes for any custom project.



LASER PROJECTOR FOR SUCTION CUP POSITIONING

Thanks to the use of the laser projector, the positioning time of the suction cups is significantly reduced. Thanks to this device, it is possible to equip the machine without downtime when working glasses in pendular mode.

INCREMENTAL PROBE FOR BENT GLASS

Touch Probe which allows real surface detection of the bent glass compared to the theoretical surface. In this way the size of the threads along the whole sheet create uniformed results.



Suction cups H 100 or 200 mm.



GEA / SPEED / MAXIMA SOFTWARE

EASYGLASS

EasyGLASS is a CAD/CAM software package, adapted especially to the CMS Glass Technology machining centers, and dedicated to the glass working industry; it enables 360° management of all CNC-machining related aspects.

Available at different levels, it offers the following functions:

- free drawing of geometric entities (arcs, bi-arcs, straight lines, rectangles, squares, ellipses, circles, regular polygons, radius, fillets, etc) or drawing from parametric predefined models for the surface definition of tables, doors, glass walls, windows, countertops, shower enclosures etc..
- management of tool table and automatic or manual tool change
- guides for suction cup positioning by an interactive graphics layout
- calculation of machining times and costs
- three-dimensional graphic simulation of the machining process

The above-described functions can be integrated by:

- laser projection of suction cup positioning or tool-path
- acquisition of thickness variation of the raw piece and adjustment for the machining to follow
- automatic and controlled management of polishing pressures
- acquisition of templates through probes

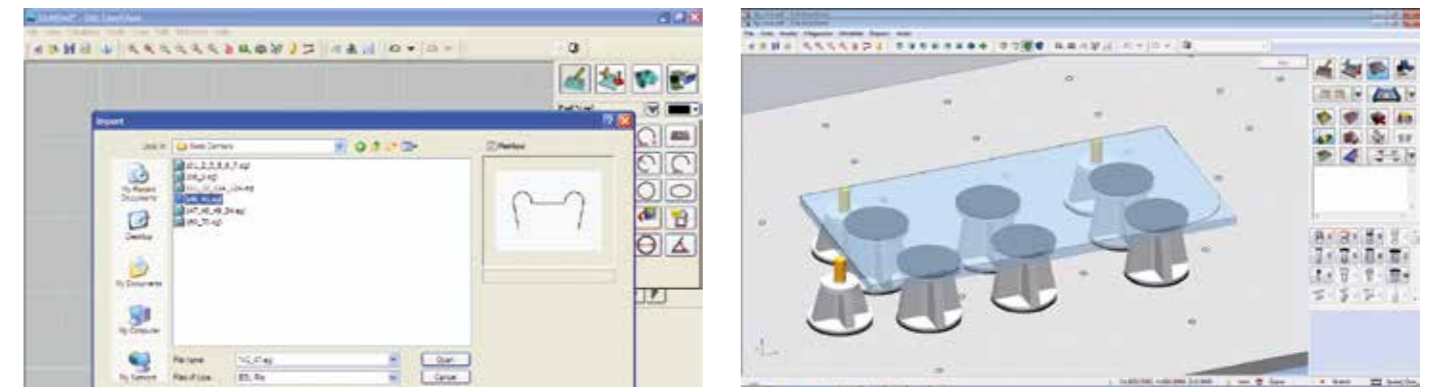
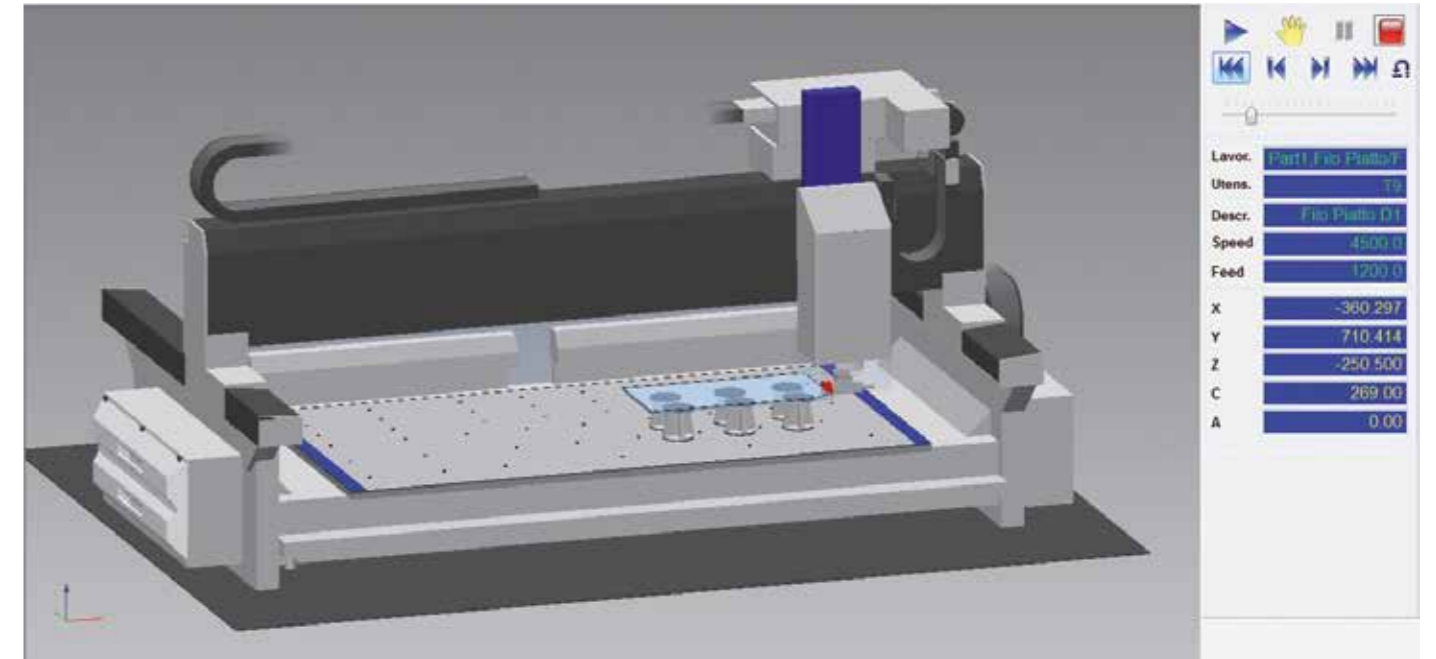
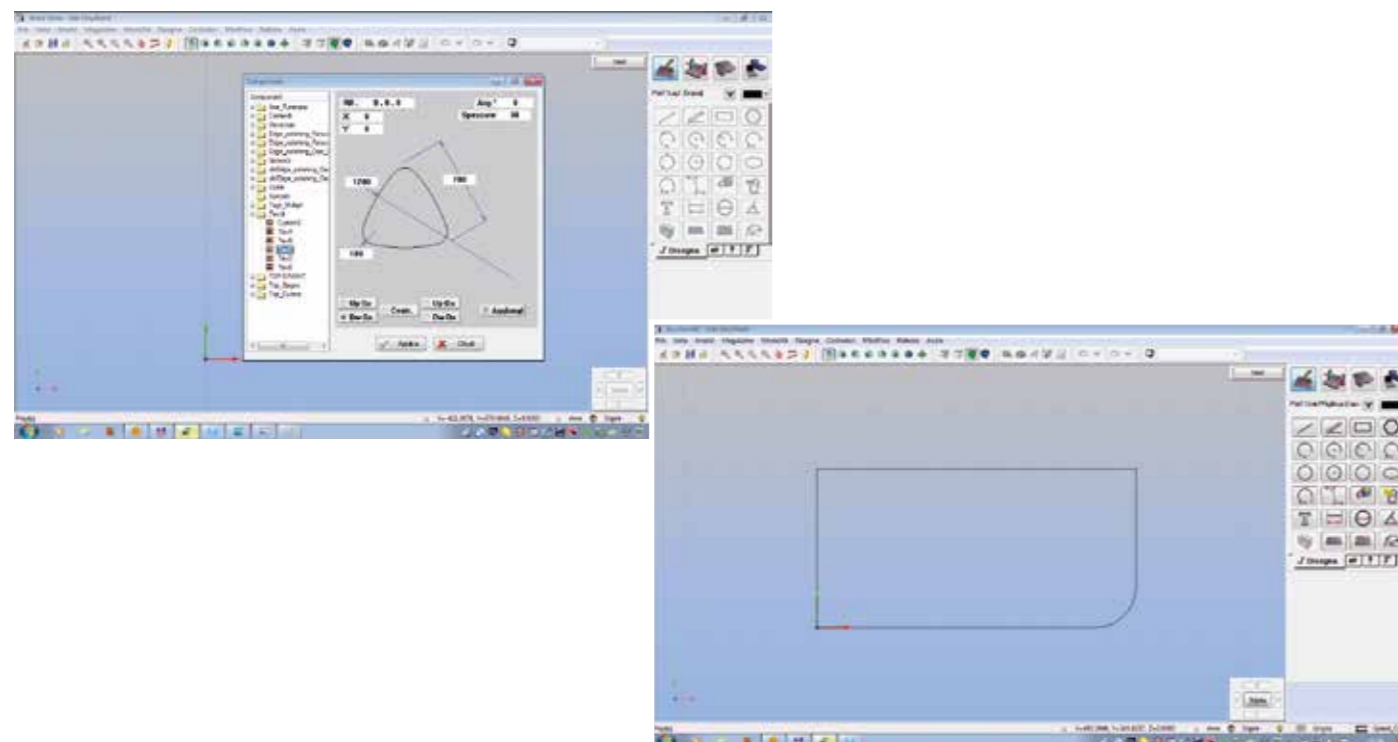

SOFTWARE SPM (SMART PRODUCTION MANAGER)

The SPM (Smart Production Manager) package is a machining management software through barcode scanning. Programming plans for the .dxf creation of a layer for each processing phase associated to a barcode that, after being scanned, automatically loads onboard the machining program; while the operator tends to the positioning of the suction cups and reference cylinders. Thanks to this software any programming downtime is eliminated, thus remarkably increasing productivity.



GEA

OVERALL DIMENSIONS AND TECHNICAL DATA

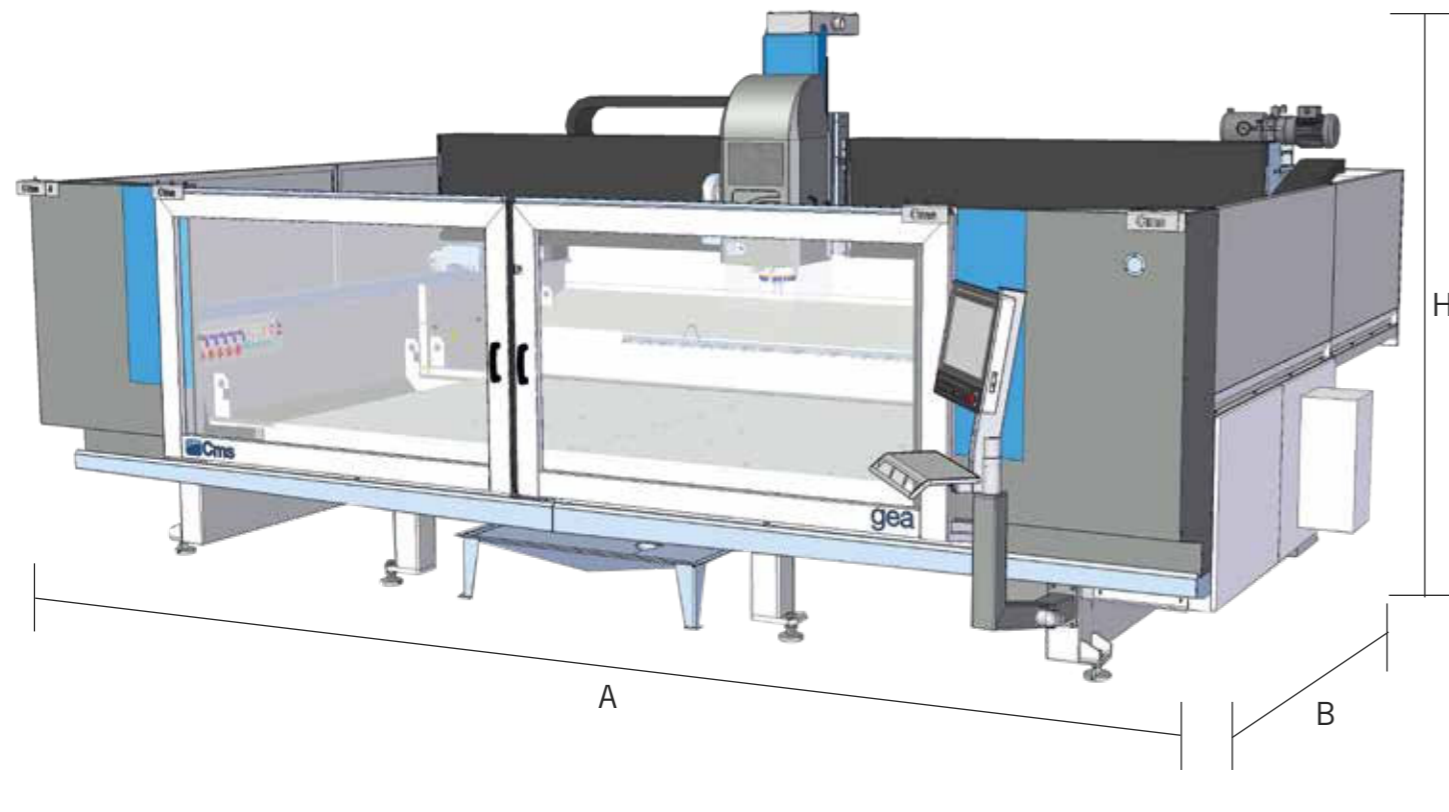

GEA: TECHNICAL DATA			
X AXIS STROKE Y AXIS STROKE Z AXIS STROKE		3800 mm / 150 in 2550 mm / 88 in 420 mm / 16 in	
MAXIMUM WORKABLE PART SIZE		3700 x 2000 mm / 146 x 79in	
ROTARY AXIS (OPTIONAL)		360° stepless	
TOOL CHANGE STATIONS	C	12 ÷ 120	
ELECTROSPINDLE POWER REVOLUTION		13,5 KW / 18 HP (S1) 21 KW / 28 HP (S6) 0 ÷ 15000 rpm	30 KW / 40 HP (S1) 36 KW / 48 HP (S6) 0 ÷ 12000 rpm
OVERALL DIMENSIONS	A B H	4715 mm / 185 in 6350 mm / 250 in (8070 mm / 318 in with open doors) 2884 mm / 113 in	
ELECTRICAL CABINET		integrated in the base	
WEIGHT		7000 kg / 15430 lb	

SPEED MB

OVERALL DIMENSIONS AND TECHNICAL DATA

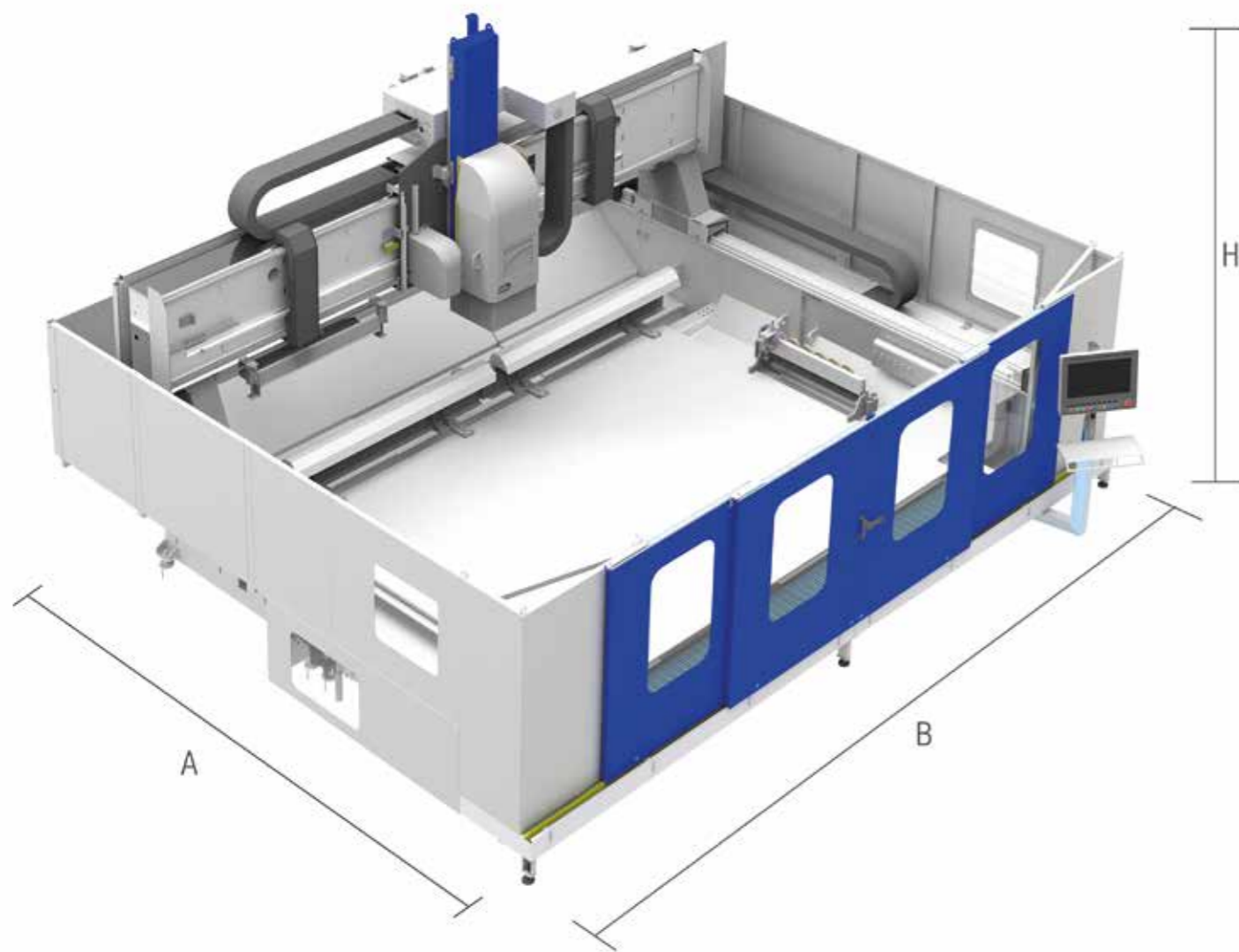

SPEED MB (MONOBLOCCO): TECHNICAL DATA

X AXIS STROKE Y AXIS STROKE Z AXIS STROKE	3800 mm / 149 in 2610 ÷ 7200 mm / 103 ÷ 283 in 520 mm / 20 in	
MAXIMUM XY WORKING DIMENSIONS	It changes according to the configuration	
ROTATING AXIS (4TH AXIS, OPTIONAL)	360° stepless	
ELECTROSPINDLE POWER REVOLUTION	13,5 KW / 18 HP (S1) 21 KW / 28 HP (S6) 0 ÷ 15000 rpm	30 KW / 40 HP (S1) 36 KW / 48 HP (S6) 0 ÷ 12000 rpm
OVERALL DIMENSIONS	A B H	4980 ÷ 9260 mm / 196 ÷ 365 in 7260 mm / 286 in open doors 2800 mm / 110 in
ELECTRICAL CABINET	integrated in the base	
WEIGHT	7000 ÷ 15000 Kg / 15432 ÷ 33070 lb	

MAXIMA

OVERALL DIMENSIONS AND TECHNICAL DATA

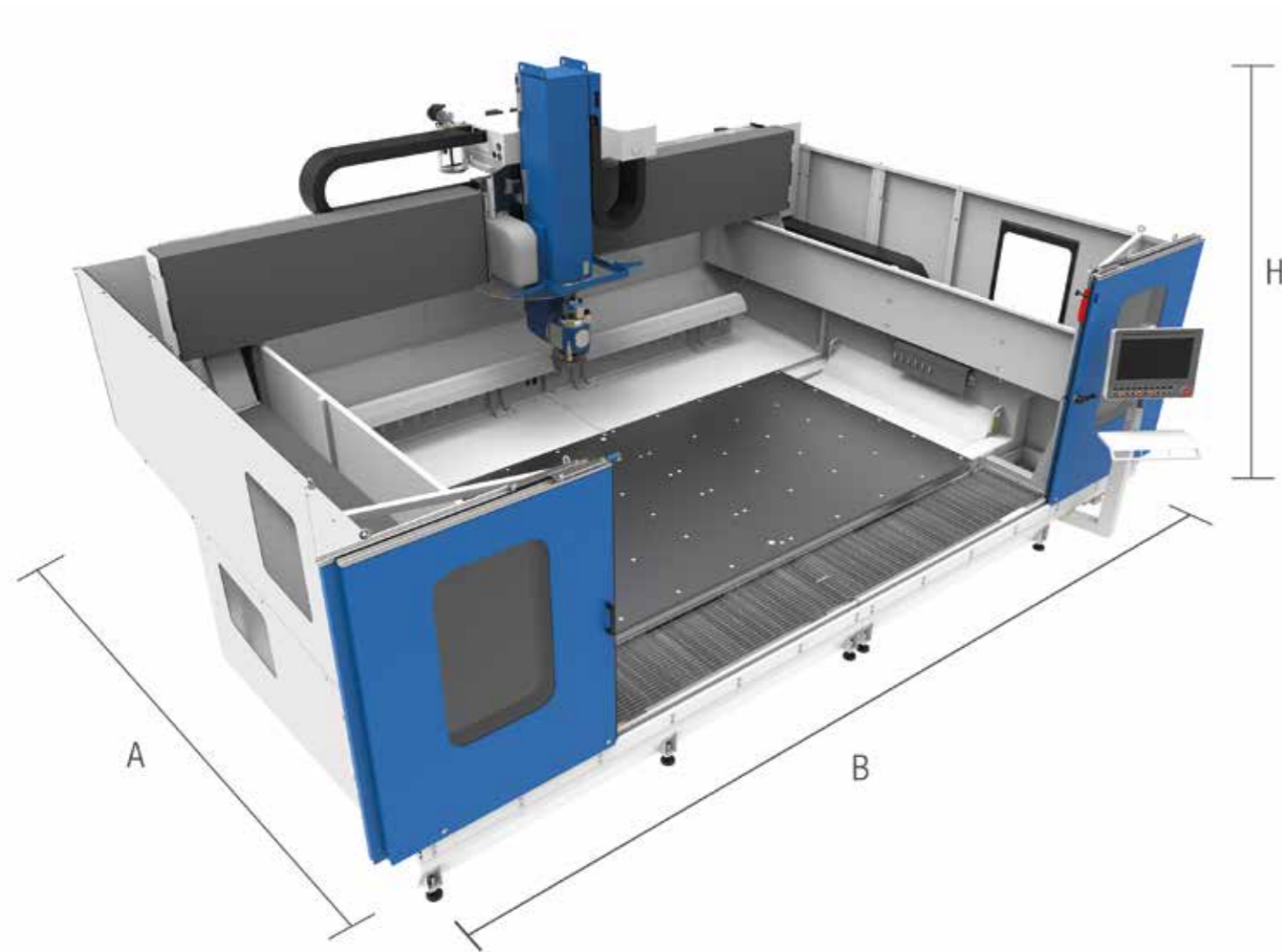

MAXIMA: TECHNICAL DATA

X AXIS STROKE		3800 mm / 149 in						
Y AXIS STROKE		2400÷7200 mm / 94÷283 in (configurations available with Y>283 in)						
Z AXIS STROKE		460÷900 mm / 18÷35 in						
MAXIMUM XY WORKING DIMENSIONS		It changes according to the configuration						
ROTATING AXIS (OPTIONAL)	B C	±100°						
TOOL CHANGE POSITIONS		13÷180 + 1 blade holder ø 500 mm						
ELECTROSPINDLE POWER REVOLUTION		<table border="1"> <tbody> <tr> <td>13,5 KW / 18 HP (S1)</td> <td>30 KW / 40 HP (S1)</td> </tr> <tr> <td>21 KW / 28 HP (S6)</td> <td>36 KW / 48 HP (S6)</td> </tr> <tr> <td>0÷15000 rpm</td> <td>0÷12000 rpm</td> </tr> </tbody> </table>	13,5 KW / 18 HP (S1)	30 KW / 40 HP (S1)	21 KW / 28 HP (S6)	36 KW / 48 HP (S6)	0÷15000 rpm	0÷12000 rpm
13,5 KW / 18 HP (S1)	30 KW / 40 HP (S1)							
21 KW / 28 HP (S6)	36 KW / 48 HP (S6)							
0÷15000 rpm	0÷12000 rpm							
OVERALL DIMENSIONS	A B H	<table border="1"> <tbody> <tr> <td>4400÷10400 mm / 173÷409 in</td> </tr> <tr> <td>8600÷9150 mm / 339÷360 in</td> </tr> <tr> <td>3800÷4050 / 150÷160 in</td> </tr> </tbody> </table>	4400÷10400 mm / 173÷409 in	8600÷9150 mm / 339÷360 in	3800÷4050 / 150÷160 in			
4400÷10400 mm / 173÷409 in								
8600÷9150 mm / 339÷360 in								
3800÷4050 / 150÷160 in								
ELECTRICAL CABINET MONOBLOC OPEN FRAME		Integrated in the base Fixed on right steel support						

CMS connect the IoT platform perfectly integrated with the latest-generation CMS machines

CMS Connect is able to offer customised micro services through the use of IoT Apps that support the daily activities of industry operators - improving the availability and use of machines or systems. The platform displays, analyses and monitors all data from connected machines. The data collected by the machines in real time become useful information to increase machine productivity, reduce operating and maintenance costs and cut energy costs.



CMS active a revolutionary interaction with your CMS machine

Cms active is our new interface. The same operator can easily control different machines as the CMS Active interfaces maintain the same look&feel, icons and iteration approach.



APPLICATIONS

SMART MACHINE: Section designed for the continuous monitoring of machine operation, with information on:

Status: machine status overviews. The representations provided allow machine availability to be checked - to identify possible bottlenecks in the production flow.

Monitoring: instantaneous, live display of the operation of the machine and its components, of currently running programs and potentiometers.

Production: list of machine programs run within a given timeframe with best time and average running time.

Alarms: active and historical warnings.

SMART MAINTENANCE

This section provides a first approach to predictive maintenance by sending notifications when machine components indicate a potentially critical state associated with reaching a certain threshold. In this way, it is possible to take action and schedule maintenance services, without any down-time.

SMART MANAGEMENT

Section designed for KPI presentation for all the machines connected to the platform. The indicators provided assess of the availability,

productivity and efficiency of the machine and the quality of the product.

MAXIMISED SECURITY

CMS Connect uses the standard OPC-UA communication protocol, which guarantees the encryption of data at Edge interface level. CMS Connect's Cloud and DataLake levels meet all state-of-the-art cyber-security requirements. Customer data are encrypted and authenticated to ensure total protection of sensitive information.

ADVANTAGES

- ✓ Optimisation of production performance
- ✓ Diagnostics to support components warranty optimisation
- ✓ Productivity increase and downtime reduction
- ✓ Improvement of quality control
- ✓ Maintenance costs down

EASY OF USE

The new interface has been especially developed and optimized to be immediately used via touch screen. Graphics and icons have been redesigned for user-friendly and comfortable navigation.

ADVANCED ORGANIZATION OF PRODUCTION

CMS Active enables configuring different users with different roles and responsibilities according to the operation mode of the machining center (e.g.: operator, maintenance man, administrator, ...). It is also possible to define the work shifts on the machining center and then survey activities, productivity and events that have occurred in each shift.

ABSOLUTE QUALITY OF THE FINISHED WORKPIECE

With CMS Active the quality of the finished workpiece is no longer jeopardized by worn-out tools. The new Tool Life Determination system of CMS Active sends warning messages when the tool life is running out and recommends its replacement at the most appropriate time.

TOOL SET-UP? NO PROBLEM!

CMS Active guides the operator during the tool magazine set-up phase, also allowing for the programs to be run.

THE RANGE OF CMS GLASS TECHNOLOGY

FOR GLASS PROCESSING

CUTTING TABLES AND CUTTING LINES



AGIL TR

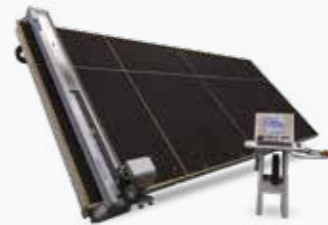

RUNNER

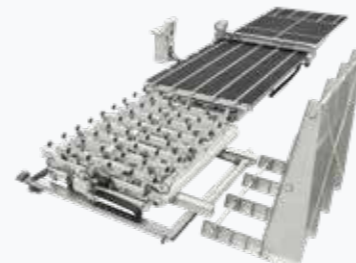

RUNNER LINE

HORIZONTAL MACHINING CENTERS



ELECTA



SPEED



GEA



MAXIMA

VERTICAL MACHINING CENTERS



TAKTIKA



YPSOS



VERTEC MILL



YPSOS + VERTEC MILL

SEAMING MACHINES



AURA



KART

WATERJET CUTTING AND PRESSURE INTENSIFIER SYSTEMS



EASYLINE



SMARTLINE



PROLINE



AQUATEC



EASYPUMP



JETPOWER EVO



E-PUMP



C.M.S. SPA
via A. Locatelli, 123 - 24019 Zogno (BG) - IT
Tel. +39 0345 64111
info@cms.it
cms.it

a company of **scm**group